

**РЕМСТАНМАШ**  
ТЕХНОЛОГИИ ДЛЯ ПРОИЗВОДСТВА

**ООО «РемСтанМаш»**

Адрес: г. Смоленск, улица Верхне-Сенная улица, дом 4, офис № 409.

Телефон: 8-800-511-02-67

Телефон: +7-919-0-46-48-46

E-mail: [info@cnchelp.ru](mailto:info@cnchelp.ru)

Сайт: [www.cnchelp.ru](http://www.cnchelp.ru)



# HEIDENHAIN

## Product Information

**RCN 2000**

**RCN 5000**

**RCN 8000**

Absolute Angle Encoders for  
Safety-Related Applications

# RCN 2000 series

**Absolute angle encoders for safety-related applications**

- Safe absolute position
- Hollow through shaft  $\varnothing 20$  mm
- System accuracy of  $\pm 2.5''$  and  $\pm 5''$

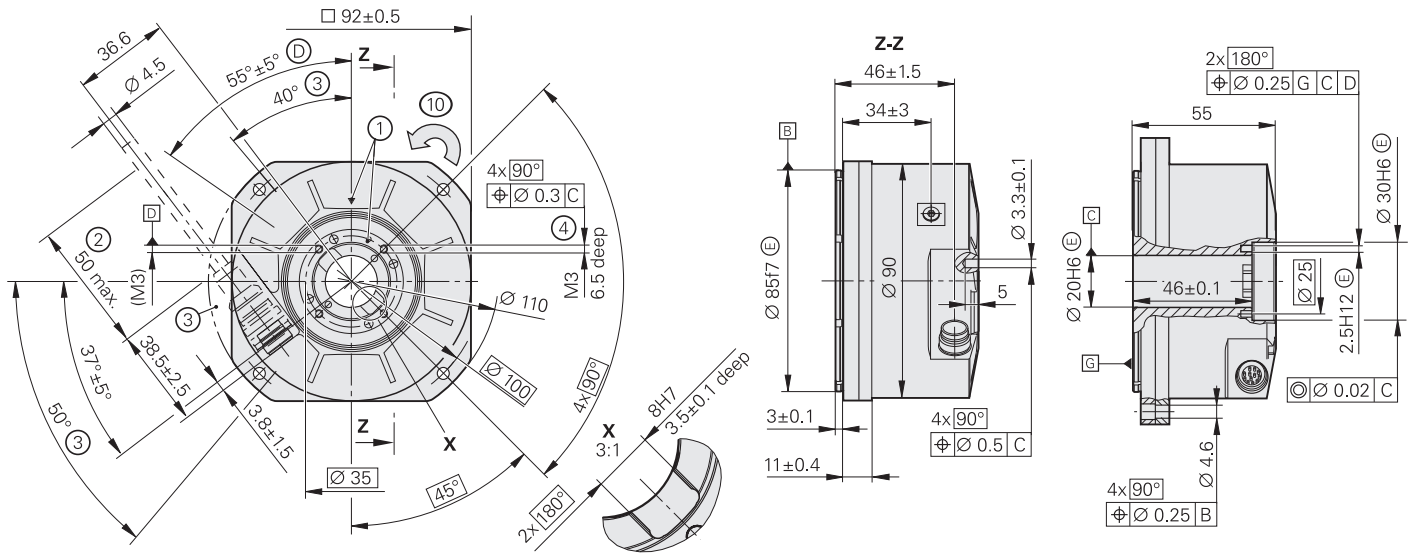
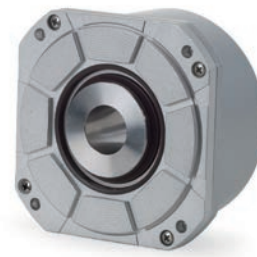

Ⓚ Shaft coupling with ring nut and catch

Shown without ring nut and catch

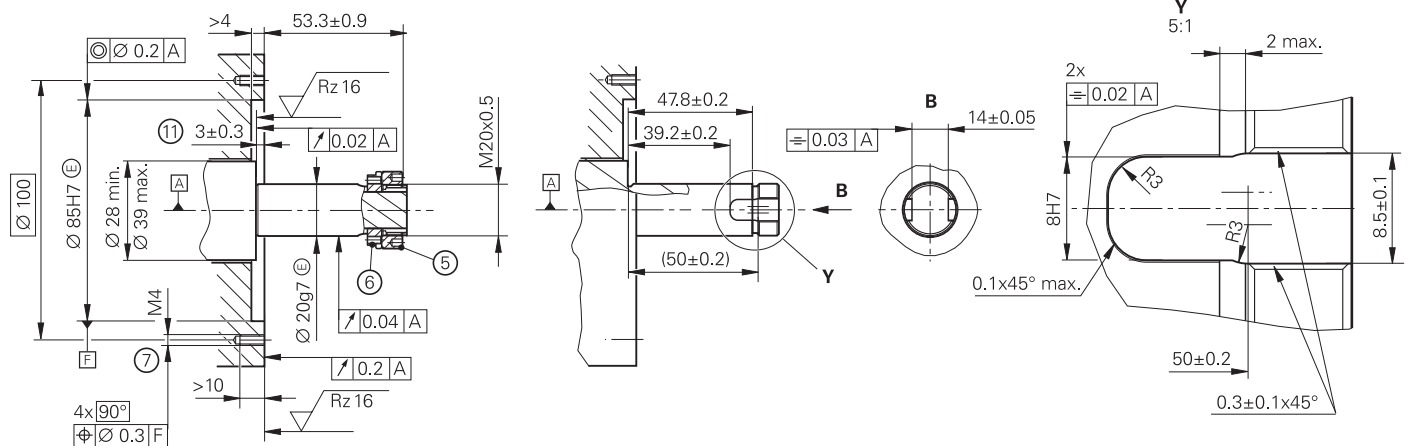

Ⓚ Alternative mounting option with front-end shaft coupling

mm  
  
 Tolerancing ISO 8015  
 ISO 2768 - m H  
 < 6 mm:  $\pm 0.2$  mm

- Ⓚ = Bearing of mating shaft
- Ⓚ = Compressed air inlet
- Ⓚ = Required mating dimensions
- 1 = Mark for  $0^\circ$  position  $\pm 5^\circ$
- 2 = Cable support
- 3 = Free space for customer
- 4 = Thread engagement:  $4.5 \pm 0.5$  mm
- 5 = Accessory: Ring nut ID 336669-03
- 6 = Accessory: Catch ID 817921-01
- 7 = Thread engagement:  $> 7.5$  mm
- 8 =  $2 \times$  spring pins ISO 8752 -  $2.5 \times 10$  - St
- 9 = Provide additional M3 back-off thread if spring pins are used
- 10 = Direction of shaft rotation for ascending position values
- 11 = Tolerance specification includes mounting tolerances and thermal expansion; no dynamic movement permitted

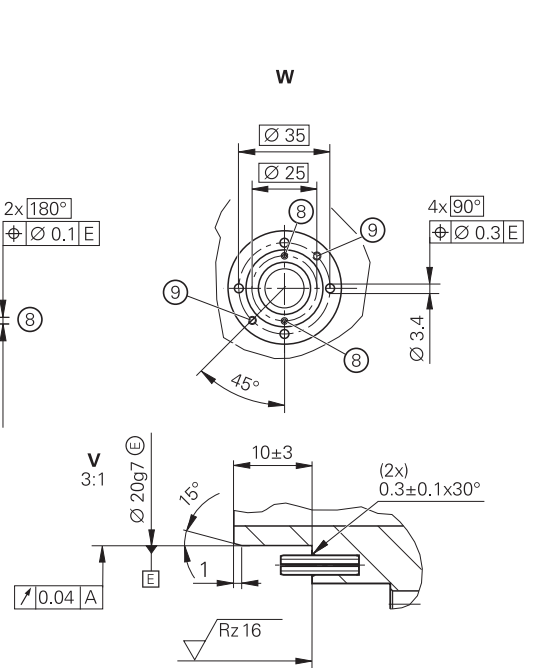

	<b>Absolute RCN 2510</b>	<b>RCN 2310</b>
<b>Measuring standard</b>	DIADUR circular scale with absolute track and incremental track (16384 lines)	
<b>System accuracy</b>	±2.5"	±5"
Position error per signal period	≤ ±0.3"	≤ ±0.4"
<b>Functional safety</b> for applications up to	<ul style="list-style-type: none"> <li>• SIL 2 as per EN 61508 (further basis for testing: EN 61800-5-2)</li> <li>• Category 3, PL d as per EN ISO 13849-1:2015</li> </ul>	
PFH	≤ 25 · 10 <sup>-9</sup>	
Safe position <sup>1)</sup>	<i>Encoder:</i> ±0.22° (safety-related measuring step SM = 0.088°) <i>Mechanical connection:</i> Fault exclusions for the loosening of housing/flange and hollow shaft (page 10/11)	
<b>Interface</b>	EnDat 2.2	
Ordering designation	EnDat22	
Positions per revolution	268435456 (28 bits)	67108864 (26 bits)
Electrically permissible speed	≤ 3000 rpm for continuous position value	
Clock frequency Calculation time t <sub>cal</sub>	≤ 16 MHz ≤ 5 μs	
<b>Electrical connection</b>	Separate adapter cable connectable to encoder via quick disconnect	
Cable length	≤ 100 m (with HEIDENHAIN cable; clock frequency: ≤ 8 MHz)	
Supply voltage	DC 3.6 V to 14 V	
Power consumption <sup>2)</sup> (maximum)	3.6 V: ≤ 1.1 W 14 V: ≤ 1.3 W	
Current consumption (typical)	5 V: 140 mA (without load)	
<b>Shaft</b>	Hollow through shaft D = 20 mm	
Mechanically permissible speed	≤ 1500 rpm <i>Temporarily:</i> ≤ 3000 rpm <sup>3)</sup> (consultation required for speeds of over 1500 rpm)	
Starting torque (at 20 °C)	≤ 0.08 Nm (typical)	
Moment of inertia	<i>Rotor (hollow shaft):</i> 180 · 10 <sup>-6</sup> kgm <sup>2</sup> <i>Stator (housing/flange):</i> 670 · 10 <sup>-6</sup> kgm <sup>2</sup>	
Permissible axial motion of measured shaft	±0.3 mm <sup>4)</sup>	
<b>Natural frequency</b>	≥ 1000 Hz	
<b>Vibration</b> 55 Hz to 2000 Hz <b>Shock</b> 6 ms	≤ 200 m/s <sup>2</sup> (EN 60068-2-6) ≤ 200 m/s <sup>2</sup> (EN 60068-2-27)	
<b>Operating temperature</b>	0 °C to 50 °C	0 °C to 60 °C -20 °C to 60 °C <sup>3)</sup>
<b>Protection</b> EN 60529	IP64	
<b>Mass</b>	≈ 1.0 kg	

<sup>1)</sup> Further tolerances may apply in the subsequent electronics after position value comparison (contact manufacturer of subsequent electronics)

<sup>2)</sup> See *General electrical information* in the *Interfaces of HEIDENHAIN Encoders* brochure

<sup>3)</sup> No fault exclusion for the loosening of the mechanical connection

<sup>4)</sup> Range includes mounting tolerances and thermal expansion; no dynamic movement permitted

# RCN 5000 series

Absolute angle encoders for safety-related applications

- Safe absolute position
- Hollow through shaft  $\varnothing 35$  mm
- System accuracy of  $\pm 2.5^\circ$  and  $\pm 5^\circ$

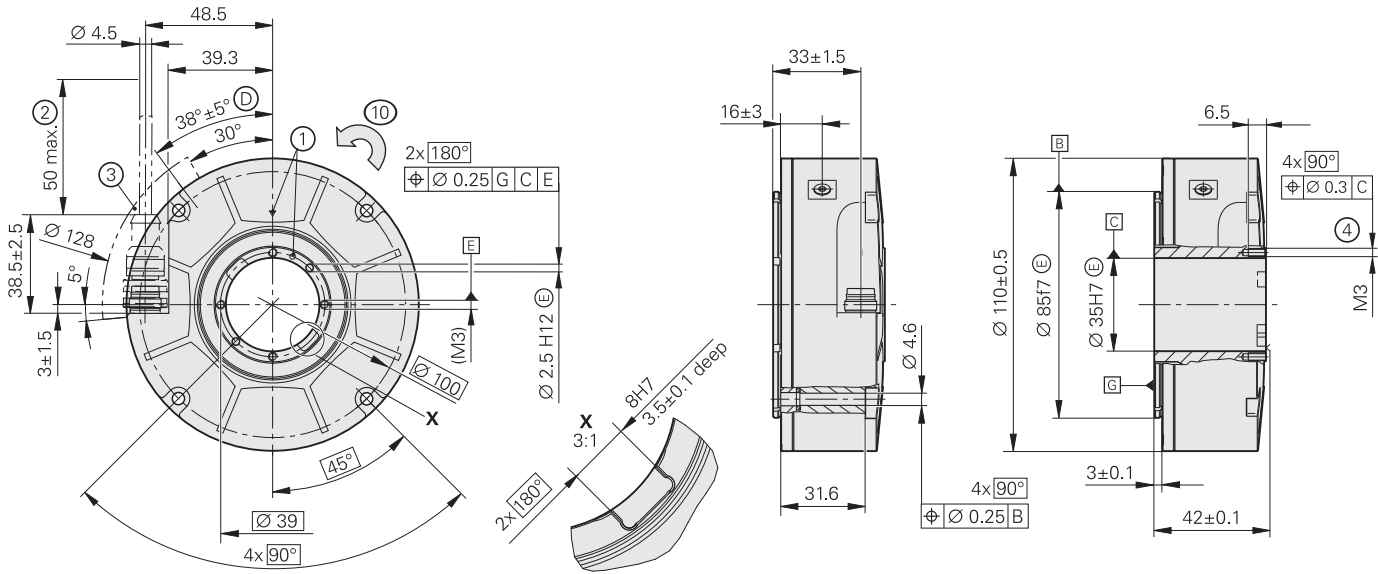

Ⓚ Shaft coupling with ring nut and catch  
Shown without ring nut and catch

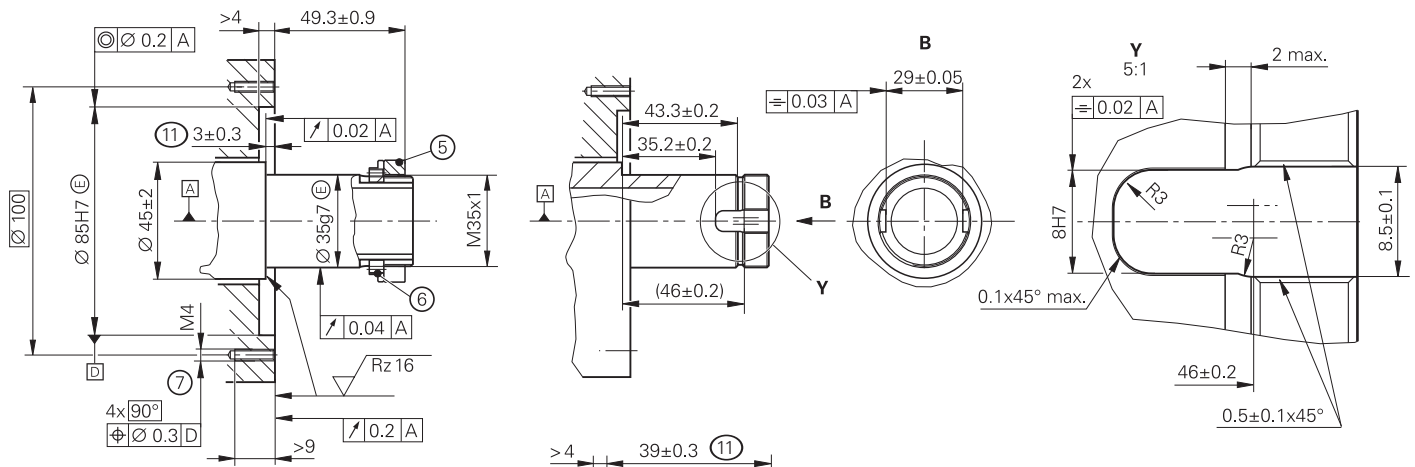

Ⓚ Alternative mounting option with front-end shaft coupling

mm  
Tolerancing ISO 8015  
ISO 2768 - m H  
< 6 mm:  $\pm 0.2$  mm

- Ⓜ = Bearing of mating shaft
- Ⓞ = Compressed air inlet
- Ⓧ = Required mating dimensions
- 1 = Mark for  $0^\circ$  position  $\pm 5^\circ$
- 2 = Cable support
- 3 = Free space for customer
- 4 = Thread engagement:  $4.5 \pm 0.5$  mm
- 5 = Accessory: Ring nut ID 336669-17
- 6 = Accessory: Catch ID 817921-02
- 7 = Thread engagement:  $> 7$  mm
- 8 =  $2 \times$  spring pins ISO 8752 -  $2.5 \times 10$  - St
- 9 = Provide additional M3 back-off thread if spring pins are used
- 10 = Direction of shaft rotation for ascending position values
- 11 = Tolerance specification includes mounting tolerances and thermal expansion; no dynamic movement permitted

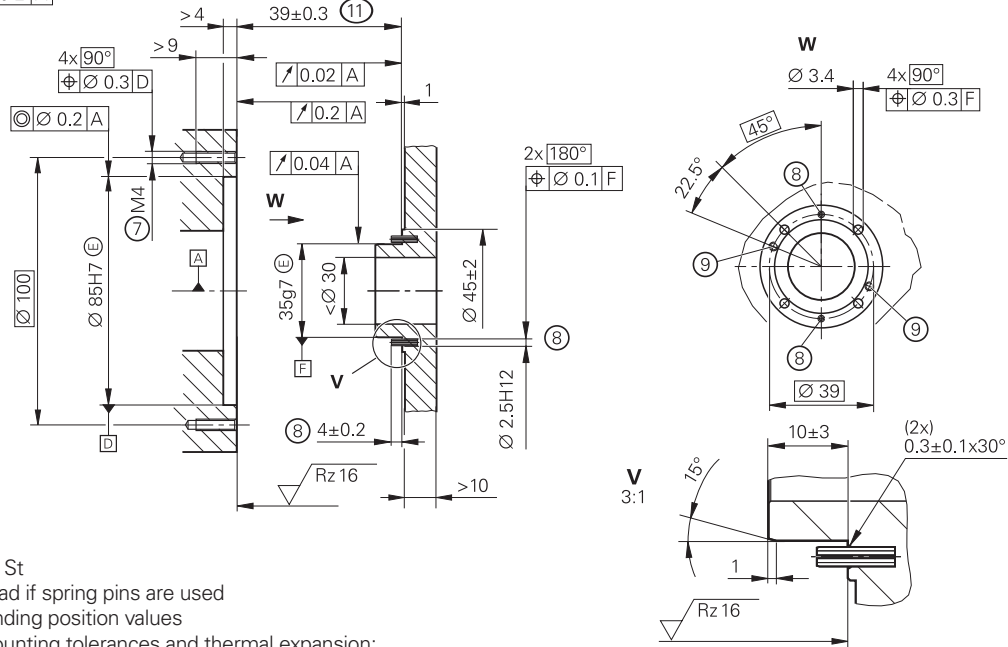

	<b>Absolute RCN 5510</b>	<b>RCN 5310</b>
<b>Measuring standard</b>	DIADUR circular scale with absolute track and incremental track (16384 lines)	
<b>System accuracy</b>	±2.5"	±5"
Position error per signal period	≤ ±0.3"	≤ ±0.4"
<b>Functional safety</b> for applications up to	<ul style="list-style-type: none"> <li>• SIL 2 as per EN 61508 (further basis for testing: EN 61800-5-2)</li> <li>• Category 3, PL d as per EN ISO 13849-1:2015</li> </ul>	
PFH	≤ 25 · 10 <sup>-9</sup>	
Safe position <sup>1)</sup>	<i>Encoder:</i> ±0.22° (safety-related measuring step SM = 0.088°) <i>Mechanical connection:</i> Fault exclusions for the loosening of housing/flange and hollow shaft (page 10/11)	
<b>Interface</b>	EnDat 2.2	
Ordering designation	EnDat22	
Positions per revolution	268435456 (28 bits)	67108864 (26 bits)
Electrically permissible speed	≤ 3000 rpm for continuous position value	
Clock frequency Calculation time t <sub>cal</sub>	≤ 16 MHz ≤ 5 μs	
<b>Electrical connection</b>	Separate adapter cable connectable to encoder via quick disconnect	
Cable length	≤ 100 m (with HEIDENHAIN cable; clock frequency: ≤ 8 MHz)	
Supply voltage	DC 3.6 V to 14 V	
Power consumption <sup>2)</sup> (maximum)	3.6 V: ≤ 1.1 W 14 V: ≤ 1.3 W	
Current consumption (typical)	5 V: 140 mA (without load)	
<b>Shaft</b>	Hollow through shaft D = 35 mm	
Mechanically permissible speed	≤ 1500 rpm <i>Temporarily:</i> ≤ 3000 rpm <sup>3)</sup> (consultation required for speeds of over 1500 rpm)	
Starting torque (at 20 °C)	≤ 0.2 Nm (typical)	
Moment of inertia	<i>Rotor (hollow shaft):</i> 130 · 10 <sup>-6</sup> kgm <sup>2</sup> <i>Stator (housing/flange):</i> 1010 · 10 <sup>-6</sup> kgm <sup>2</sup>	
Permissible axial motion of measured shaft	±0.3 mm <sup>4)</sup>	
<b>Natural frequency</b>	≥ 1000 Hz	
<b>Vibration</b> 55 Hz to 2000 Hz <b>Shock</b> 6 ms	≤ 200 m/s <sup>2</sup> (EN 60068-2-6) ≤ 200 m/s <sup>2</sup> (EN 60068-2-27)	
<b>Operating temperature</b>	0 °C to 50 °C	0 °C to 60 °C -20 °C to 60 °C <sup>3)</sup>
<b>Protection</b> EN 60529	IP64	
<b>Mass</b>	≈ 0.9 kg	

<sup>1)</sup> Further tolerances may apply in subsequent electronics after position value comparison (contact manufacturer of subsequent electronics).

<sup>2)</sup> See *General electrical information* in the *Interfaces of HEIDENHAIN Encoders* brochure

<sup>3)</sup> No fault exclusion for the loosening of the mechanical connection

<sup>4)</sup> Range includes mounting tolerances and thermal expansion; no dynamic movement permitted

# RCN 8000 series

**Absolute angle encoders for safety-related applications**

- Safe absolute position
- Hollow through shaft  $\varnothing 60$  mm
- System accuracy of  $\pm 1^\circ$  and  $\pm 2^\circ$

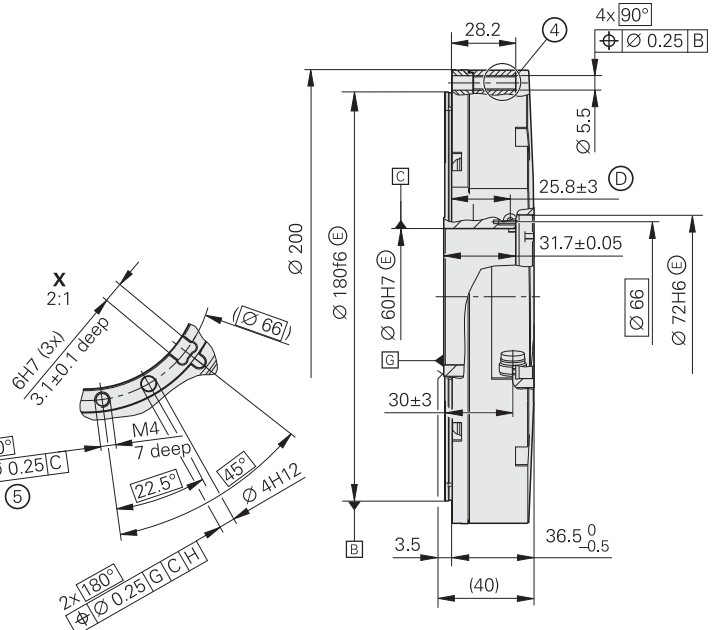
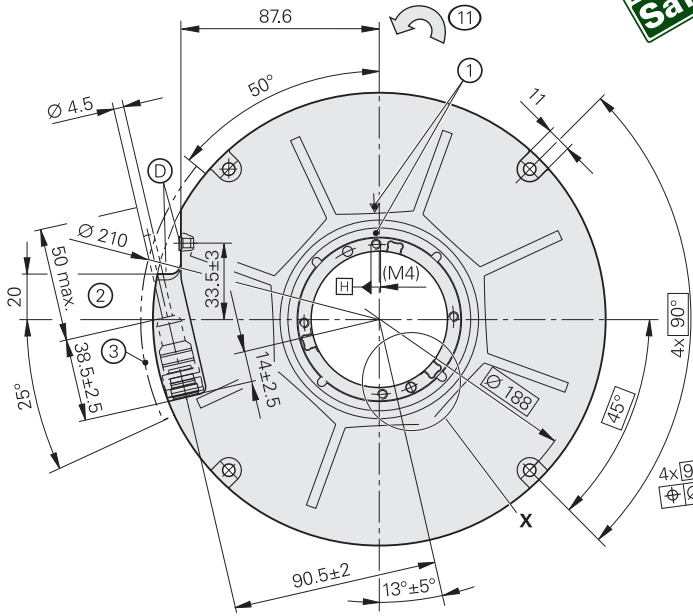
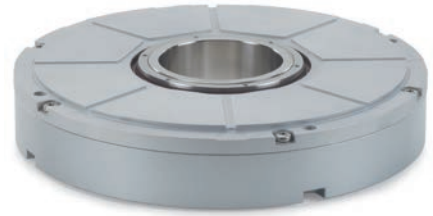

(K) Shaft coupling with ring nut and catch

(K) Alternative mounting option with front-end shaft coupling

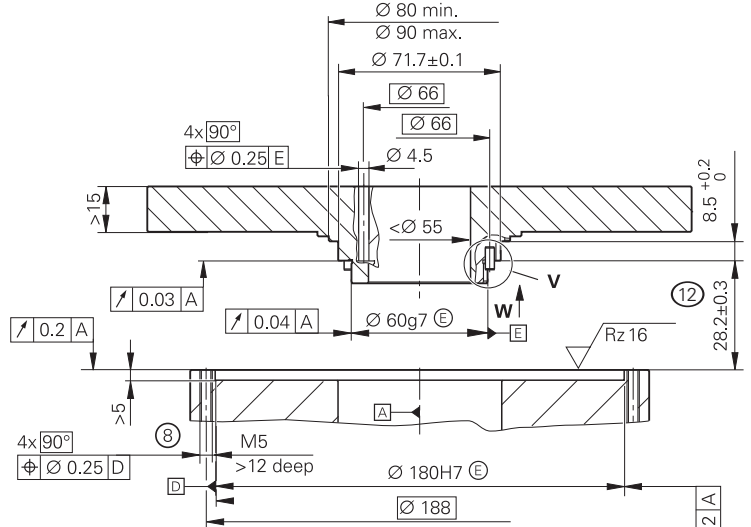
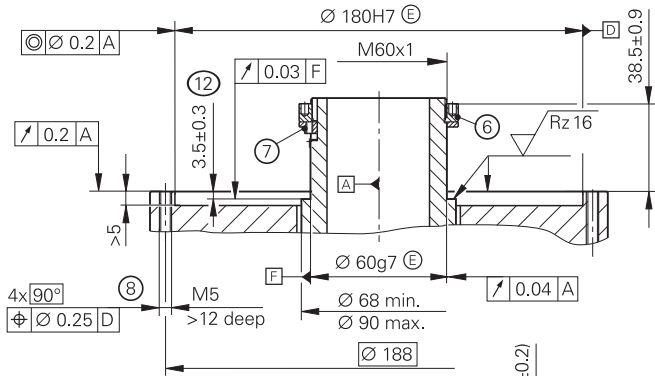

Shown without ring nut and catch

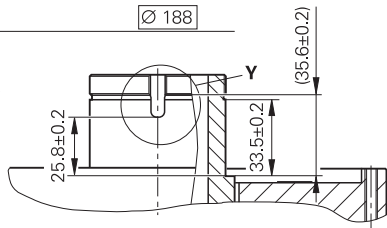

mm  
  
 Tolerancing ISO 8015  
 ISO 2768 - m H  
 < 6 mm:  $\pm 0.2$  mm

- Ⓐ = Bearing
- Ⓢ = Compressed air inlet
- Ⓣ = Required mating dimensions
- 1 = Mark for  $0^\circ$  position  $\pm 5^\circ$
- 2 = Cable support
- 3 = Free space for customer
- 4 = Shown rotated by  $45^\circ$
- 5 = Thread engagement:  $5.5 \pm 0.5$  mm
- 6 = Accessory: Ring nut ID 336669-11
- 7 = Accessory: Catch ID 817921-03
- 8 = Thread engagement: > 10 mm
- 9 = 2x spring pins ISO 8752 - 4x10 - St
- 10 = Provide additional M4 back-off thread if spring pins are used
- 11 = Direction of shaft rotation for ascending position values
- 12 = Tolerance specification includes mounting tolerances and thermal expansion; no dynamic movement permitted

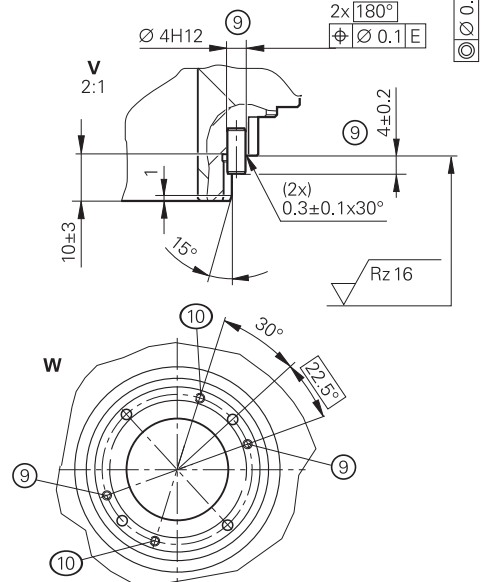

	<b>Absolute</b>	
	<b>RCN 8510</b>	<b>RCN 8310</b>
<b>Measuring standard</b>	DIADUR circular scale with absolute track and incremental track (32768 lines)	
<b>System accuracy</b>	±1"	±2"
Position error per signal period	≤ ±0.15"	≤ ±0.2"
<b>Functional safety</b> for applications up to	<ul style="list-style-type: none"> <li>• SIL 2 as per EN 61508 (further basis for testing: EN 61800-5-2)</li> <li>• Category 3, PL d as per EN ISO 13849-1:2015 for standstill monitoring and speed monitoring</li> <li>• Category 2, PL d as per EN ISO 13849-1:2015 for safe absolute position</li> <li>• Category 3, PL d as per EN ISO 13849-1:2015 for safe absolute position in conjunction with HEIDENHAIN controls or Siemens Sinamics S120)</li> </ul>	
PFH	≤ 25 · 10 <sup>-9</sup>	
Safe position <sup>1)</sup>	<i>Encoder:</i> ±0.11° (safety-related measuring step: SM = 0.044°) <i>Mechanical connection:</i> Fault exclusions for the loosening of housing/flange and hollow shaft (page 10/11)	
<b>Interface</b>	EnDat 2.2	
Ordering designation	EnDat22	
Positions per revolution	536870912 (29 bits)	
Electrically permissible speed	≤ 1500 rpm for continuous position value	
Clock frequency Calculation time t <sub>cal</sub>	≤ 16 MHz ≤ 5 μs	
<b>Electrical connection</b>	Separate adapter cable connectable to encoder via quick disconnect	
Cable length	≤ 100 m (with HEIDENHAIN cable; clock frequency: ≤ 8 MHz)	
Supply voltage	DC 3.6 V to 14 V	
Power consumption <sup>2)</sup> (maximum)	3.6 V: ≤ 1.1 W 14 V: ≤ 1.3 W	
Current consumption (typical)	5 V: 140 mA (without load)	
<b>Shaft</b>	Hollow through shaft D = 60 mm	
Mechanically permissible speed	≤ 500 rpm <i>Temporarily:</i> ≤ 1500 rpm <sup>3)</sup> (consultation required for speeds of over 500 rpm)	
Starting torque (at 20 °C)	≤ 0.7 Nm (typical)	
Moment of inertia	<i>Rotor (hollow shaft):</i> 1.22 · 10 <sup>-3</sup> kgm <sup>2</sup> <i>Stator (housing/flange):</i> 11.0 · 10 <sup>-3</sup> kgm <sup>2</sup>	
Permissible axial motion of measured shaft	±0.3 mm <sup>4)</sup>	
<b>Natural frequency</b>	≥ 900 Hz	
<b>Vibration</b> 55 Hz to 2000 Hz <b>Shock</b> 6 ms	≤ 200 m/s <sup>2</sup> (EN 60068-2-6) ≤ 200 m/s <sup>2</sup> (EN 60068-2-27)	
<b>Operating temperature</b>	0 °C to 50 °C	
<b>Protection</b> EN 60529	IP64	
<b>Mass</b>	≈ 2.8 kg	

<sup>1)</sup> Further tolerances may apply in the subsequent electronics after position value comparison (contact manufacturer of subsequent electronics).

<sup>2)</sup> See *General electrical information* in the *Interfaces of HEIDENHAIN Encoders* brochure

<sup>3)</sup> No fault exclusion for the loosening of the mechanical connection

<sup>4)</sup> Range includes mounting tolerances and thermal expansion; no dynamic movement permitted  
Sinamics is a registered trademark of Siemens AG

# RCN 8000 series

**Absolute angle encoders for safety-related applications**

- Safe absolute position
- Hollow through shaft  $\varnothing 100$  mm
- System accuracy of  $\pm 1^\circ$  and  $\pm 2^\circ$

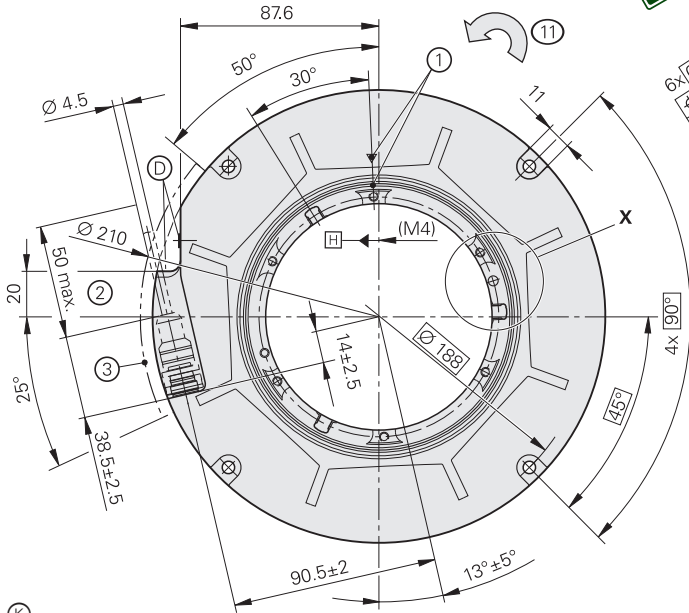

Ⓚ Shaft coupling with ring nut and catch

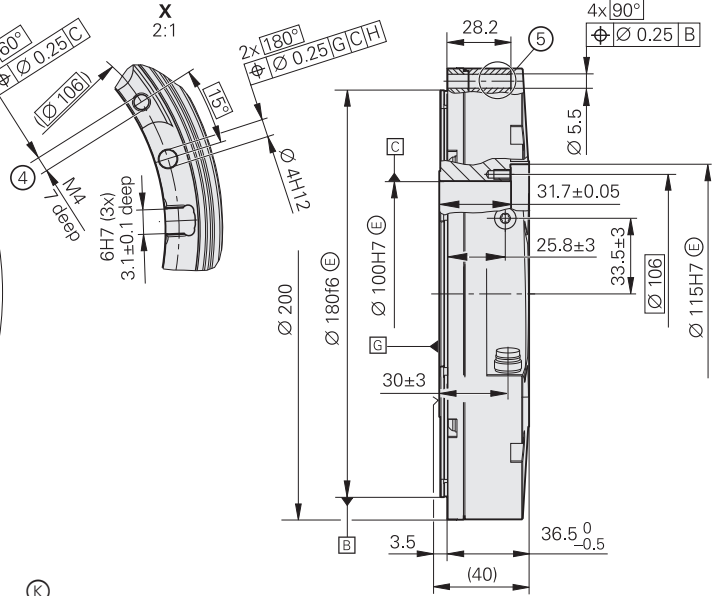

Ⓚ Alternative mounting option with front-end shaft coupling

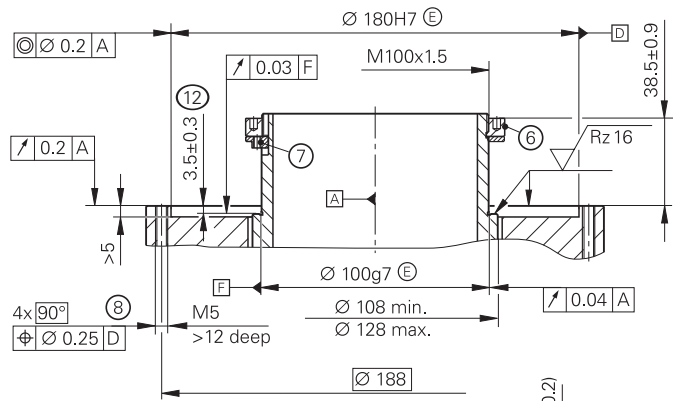

Shown without ring nut and catch

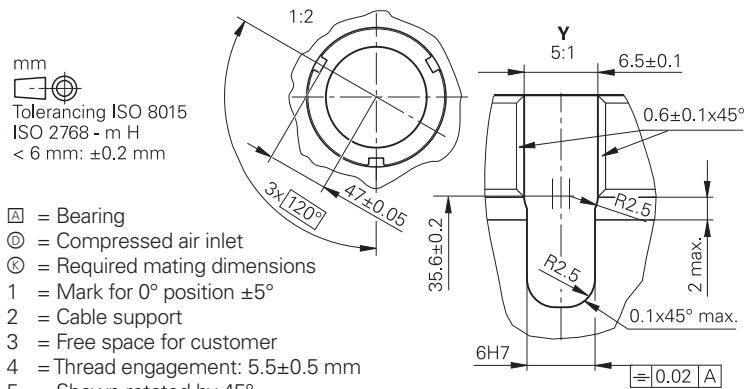
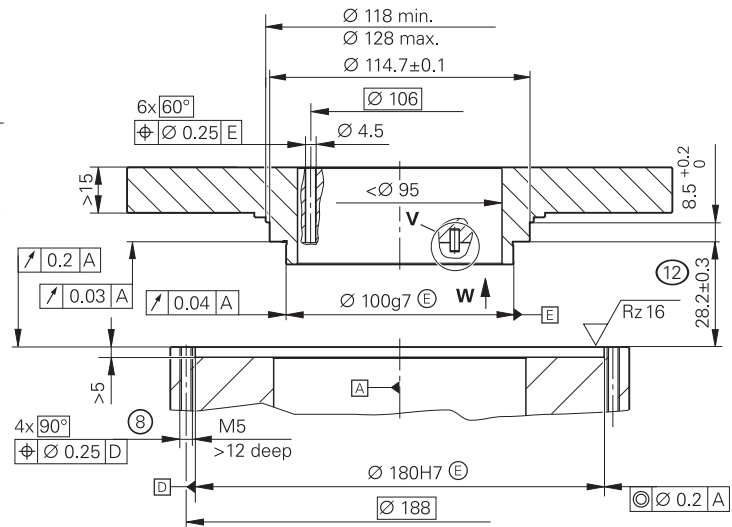

- Ⓚ = Bearing
- Ⓚ = Compressed air inlet
- Ⓚ = Required mating dimensions
- 1 = Mark for 0° position  $\pm 5^\circ$
- 2 = Cable support
- 3 = Free space for customer
- 4 = Thread engagement:  $5.5 \pm 0.5$  mm
- 5 = Shown rotated by  $45^\circ$
- 6 = Accessory: Ring nut ID 336669-16
- 7 = Accessory: Catch ID 817921-04
- 8 = Thread engagement:  $> 10$  mm
- 9 = 2x spring pins ISO 8752 - 4x10 - St
- 10 = Provide additional M4 back-off thread if spring pins are used
- 11 = Direction of shaft rotation for ascending position values
- 12 = Tolerance specification includes mounting tolerances and thermal expansion; no dynamic movement permitted.

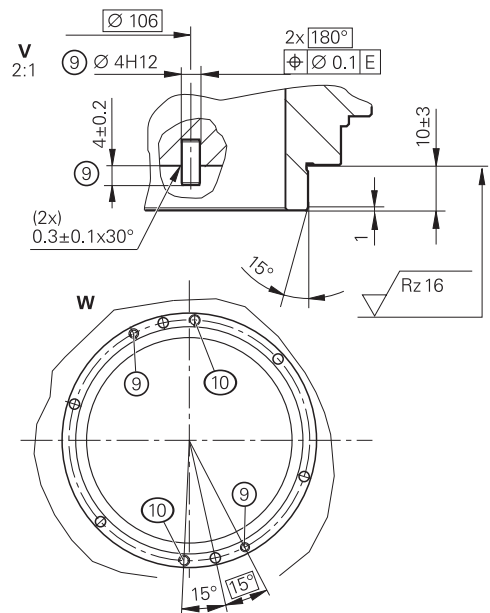



	<b>Absolute</b>	
	<b>RCN 8510</b>	<b>RCN 8310</b>
<b>Measuring standard</b>	DIADUR circular scale with absolute track and incremental track (32768 lines)	
<b>System accuracy</b>	±1"	±2"
Position error per signal period	≤ ±0.15"	≤ ±0.2"
<b>Functional safety</b> for applications up to	<ul style="list-style-type: none"> <li>• SIL 2 as per EN 61508 (further basis for testing: EN 61800-5-2)</li> <li>• Category 3, PL d as per EN ISO 13849-1:2015 for standstill monitoring and speed monitoring</li> <li>• Category 2, PL d as per EN ISO 13849-1:2015 for safe absolute position</li> <li>(Category 3, PL d as per EN ISO 13849-1:2015 for safe absolute position in conjunction with HEIDENHAIN controls or Siemens Sinamics S120)</li> </ul>	
PFH	≤ 25 · 10 <sup>-9</sup>	
Safe position <sup>1)</sup>	<i>Encoder:</i> ±0.11° (safety-related measuring step SM = 0.044°) <i>Mechanical connection:</i> Fault exclusions for the loosening of housing/flange and hollow shaft (page 10/11)	
<b>Interface</b>	EnDat 2.2	
Ordering designation	EnDat22	
Positions per revolution	536870912 (29 bits)	
Electrically permissible speed	≤ 1500 rpm for continuous position value	
Clock frequency Calculation time t <sub>cal</sub>	≤ 16 MHz ≤ 5 μs	
<b>Electrical connection</b>	Separate adapter cable connectable to encoder via quick disconnect	
Cable length	≤ 100 m (with HEIDENHAIN cable; clock frequency: ≤ 8 MHz)	
Supply voltage	DC 3.6 V to 14 V	
Power consumption <sup>2)</sup> (maximum)	3.6 V: ≤ 1.1 W 14 V: ≤ 1.3 W	
Current consumption (typical)	5 V: 140 mA (without load)	
<b>Shaft</b>	Hollow through shaft D = 100 mm	
Mechanically permissible speed	≤ 500 rpm <i>Temporarily:</i> ≤ 1500 rpm <sup>3)</sup> (consultation required for speeds of over 500 rpm)	
Starting torque (at 20 °C)	≤ 1.0 Nm (typical)	
Moment of inertia	<i>Rotor (hollow shaft):</i> 3.20 · 10 <sup>-3</sup> kgm <sup>2</sup> <i>Stator (housing/flange):</i> 10.0 · 10 <sup>-3</sup> kgm <sup>2</sup>	
Permissible axial motion of measured shaft	±0.3 mm <sup>4)</sup>	
<b>Natural frequency</b>	≥ 900 Hz	
<b>Vibration</b> 55 Hz to 2000 Hz <b>Shock</b> 6 ms	≤ 200 m/s <sup>2</sup> (EN 60068-2-6) ≤ 200 m/s <sup>2</sup> (EN 60068-2-27)	
<b>Operating temperature</b>	0 °C to 50 °C	
<b>Protection</b> EN 60529	IP64	
<b>Mass</b>	≈ 2.6 kg	

<sup>1)</sup> Further tolerances may apply in the subsequent electronics after position value comparison (contact manufacturer of subsequent electronics).

<sup>2)</sup> See *General electrical information* in the *Interfaces of HEIDENHAIN Encoders* brochure

<sup>3)</sup> No fault exclusion for the loosening of the mechanical connection

<sup>4)</sup> Range includes mounting tolerances and thermal expansion; no dynamic movement permitted  
Sinamics is a registered trademark of Siemens AG

# Functional safety

With its RCN 2000/5000/8000 series of absolute angle encoders, HEIDENHAIN offers the ideal solution for position acquisition for rotary axes in safety-related applications. In conjunction with a safe control, the encoders can be used as single-encoder systems in applications with control category SIL 2 (as per EN 61508) or performance level d (as per EN ISO 13849).

Reliable transmission of the position is based on two independently generated absolute position values and on error bits that are provided to the safe control. The functions of the encoder can be used for numerous safety functions in the complete system as per EN 61800-5-2 (see table).

The RCN 2000/5000/8000 angle encoders provide a safe absolute position value at all times—including immediately upon switch-on. Purely serial data transfer takes place via the bidirectional EnDat 2.2 interface.

In addition to the data interface, the mechanical connection of the encoder to the motor is also relevant to safety. Table D16 of the EN 61800-5-2 standard for electrical drives includes the loosening of the mechanical connection between the

encoder and drive as a fault that requires consideration. Since the control is not necessarily able to detect such errors, fault exclusion for the loosening of the mechanical connection is required in many cases.

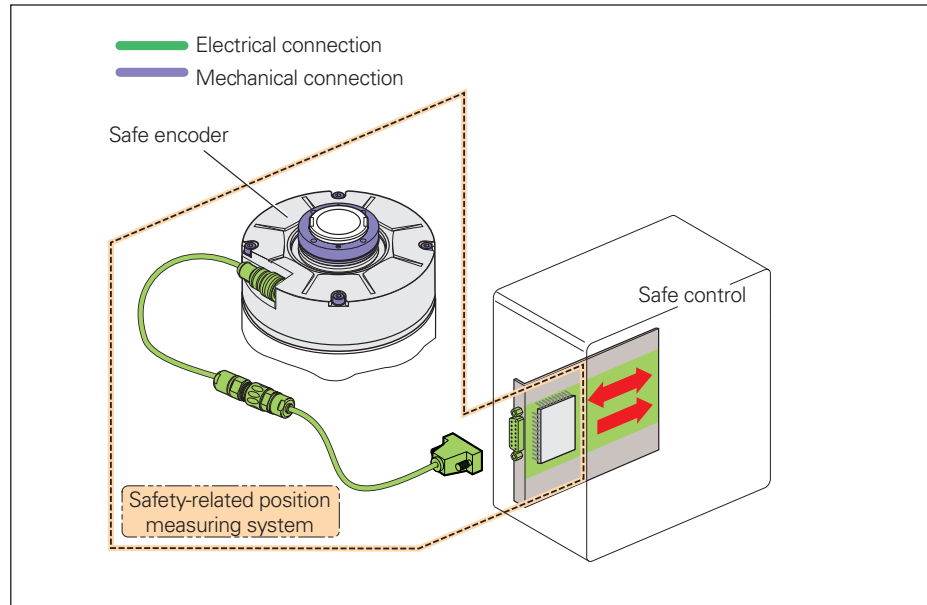

Safety-related position measuring system with mechanical connection and electrical interface

## Fault exclusion for the loosening of the mechanical connection

There are various ways of connecting the RCN 2000, RCN 5000, and RCN 8000 series for providing this kind of fault exclusion. Whereas the housing or flange is standardly mounted with fastening screws, special factors must be taken into consideration for the hollow-shaft connection. For more information on this topic and on limitations to the specifications, please refer to the following table.

Fault exclusion is thereby possible for the loosening of the mechanical connection between the encoder and the machine shaft or customer-side fastening components. For the design of the mechanical fault exclusion for other purely customer-side connections, the following torque of the encoder must be taken into account:

$$M_{Max} = J \cdot \alpha + M_{Friction}$$

J: Moment of inertia of the encoder (rotor or stator; see the specifications) and of the mechanical connection (e.g., ring nut and catch when acceleration is applied over the hollow shaft and shaft coupling via the given components)  
 $\alpha$ : Max. angular acceleration in the application

$M_{Friction}$ : RCN 2000:	4.5 Nm
RCN 5000:	4.5 Nm
RCN 8000 (Ø 60 mm):	7.5 Nm
RCN 8000 (Ø 100 mm):	8.5 Nm

Mechanical connection	Fastening <sup>1)</sup>	Safe position for the mechanical coupling <sup>2)</sup>	Restricted specifications <sup>3)</sup>
<b>Housing/flange</b>	RCN 2000/5000: ISO 4762 8.8 M4 screws RCN 8000: ISO 4762 8.8 M5 screws	±0°	See the specifications: • Mechanically permissible speed • Operating temperature (only for RCN 2000/5000)
<b>Hollow shaft</b> Shaft coupling with ring nut	Ring nut and catch (see <i>Mounting</i> )	RCN 2000: ±0.55° RCN 5000: ±0.35° RCN 8000: Ø 60 mm: ±0.15° Ø 100 mm: ±0.10°	See <i>Mounting</i> : • Usable materials • Permissible angular acceleration
<b>Hollow shaft</b> Front-end shaft coupling	RCN 2000/5000: ISO 4762 8.8 M3 screws ISO 8752 – 2.5x10 – St spring pins RCN 8000: ISO 4762 8.8 M4 screws ISO 8752 – 4x10 – St spring pins	RCN 2000: ±0.07° RCN 5000: ±0.06° RCN 8000: ±0.02°	

<sup>1)</sup> A suitable anti-rotation lock must be used for the screw connections (in the case of mounting/servicing)

<sup>2)</sup> Fault exclusions are given only for the explicitly mentioned mounting options

<sup>3)</sup> Compared with standard encoders (see the *Angle Encoders with Integral Bearing* brochure)

# Mounting

## Mounting

For the RCN angle encoders, the shaft connection is implemented with a ring nut and catch.

Alternatively, a front-end shaft coupling with mounting screws and spring pins is also possible.

- Catch for RCN 2000: ID 817921-01
- Catch for RCN 5000: ID 817921-02
- Catch for RCN 8000:
  - Hollow shaft  $\varnothing$  60 mm: ID 817921-03
  - Hollow shaft  $\varnothing$  100 mm: ID 817921-04

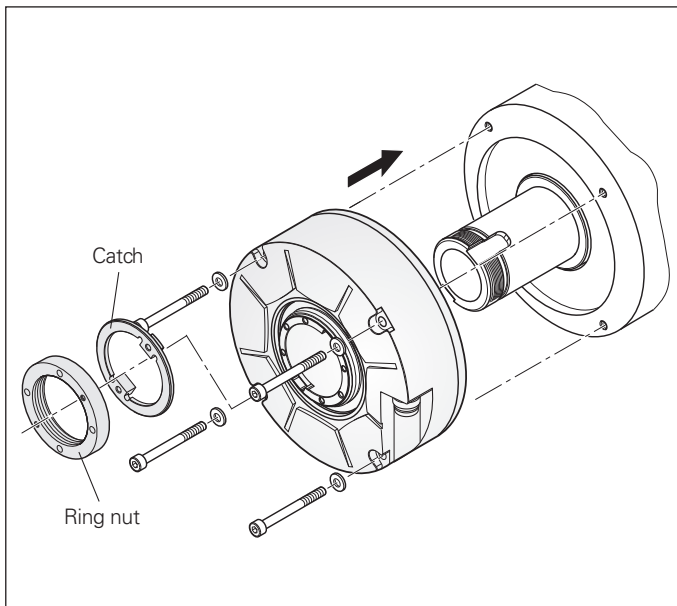

Shaft coupling with ring nut and catch

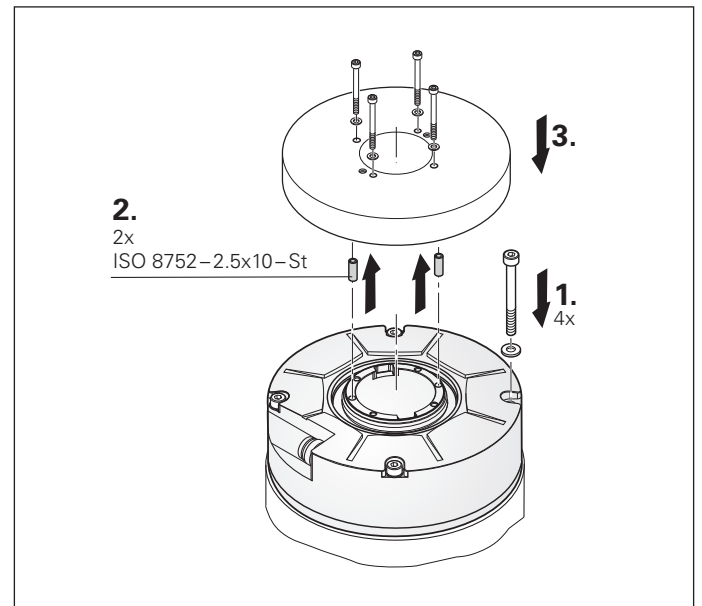

Front-end shaft coupling with mounting screws and spring pins

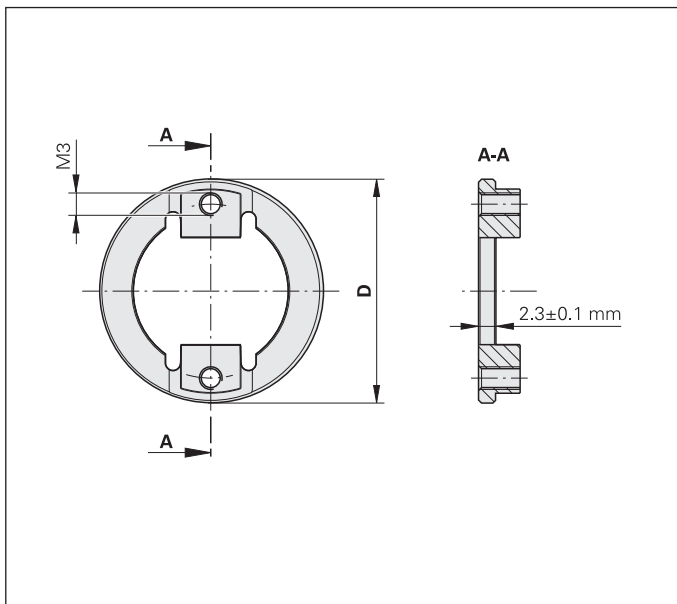

Catch

	D (mm)	Moment of inertia of ring nut and catch
RCN 2000	29.6	$4.8 \cdot 10^{-6} \text{ kgm}^2$
RCN 5000	45.8	$24 \cdot 10^{-6} \text{ kgm}^2$
RCN 8000 ( $\varnothing$ 60 mm)	70	$87 \cdot 10^{-6} \text{ kgm}^2$
RCN 8000 ( $\varnothing$ 100 mm)	114	$550 \cdot 10^{-6} \text{ kgm}^2$

### Materials to be used

The materials stated in this table must be used for the machine shaft and fastening components.

	Mating shaft	Mating stator
<b>Material</b>	Ferrous materials (steel/cast iron materials)	
<b>Tensile strength <math>R_m</math></b>	$\geq 600 \text{ N/mm}^2$	$\geq 250 \text{ N/mm}^2$
<b>Shear strength <math>\tau_B</math></b>	$\geq 390 \text{ N/mm}^2$	$\geq 290 \text{ N/mm}^2$
<b>Interface pressure <math>p_G</math></b>	$\geq 660 \text{ N/mm}^2$	$\geq 275 \text{ N/mm}^2$
<b>Elastic modulus E</b>	110 000 N/mm <sup>2</sup> to 215 000 N/mm <sup>2</sup>	
<b>Coefficient of expansion <math>\alpha_{\text{therm}}</math> (at 20 °C)</b>	10 · 10 <sup>-6</sup> K <sup>-1</sup> to 17 · 10 <sup>-6</sup> K <sup>-1</sup>	
<b>Mounting temperature</b>	All of the specifications on screw connections are based on a mounting temperature of 15 °C to 35 °C	

### Permissible angular acceleration

Based on where acceleration is applied and the mounting type, the following values apply to the angular acceleration:

- Permissible angular acceleration of the rotor when acceleration is applied via the hollow shaft and shaft coupling with ring nut and catch:
 

RCN 2000 series:	20 000 rad/s <sup>2</sup>
RCN 5000 series:	25 000 rad/s <sup>2</sup>
RCN 8000 series:	
– Ø 60 mm:	4 500 rad/s <sup>2</sup>
– Ø 100 mm:	3 500 rad/s <sup>2</sup>
- Permissible angular acceleration of the rotor when acceleration is applied via the hollow shaft and a front-end shaft coupling with fastening screws and spring pins:
 



RCN 2000 series:	5 500 rad/s <sup>2</sup>
RCN 5000 series:	10 000 rad/s <sup>2</sup>
RCN 8000 series:	
– Ø 60 mm:	3 000 rad/s <sup>2</sup>
– Ø 100 mm:	3 000 rad/s <sup>2</sup>



- Permissible angular acceleration of the stator when acceleration is applied via the flange/housing:

RCN 2000 series:	4 000 rad/s <sup>2</sup>
RCN 5000 series:	2 500 rad/s <sup>2</sup>
RCN 8000 series:	
– Ø 60 mm:	1 000 rad/s <sup>2</sup>
– Ø 100 mm:	1 000 rad/s <sup>2</sup>

# Electrical connection

## Cables

<b>PUR adapter cables</b> $\varnothing 4.5 \text{ mm}; 1 \times (4 \times 0.09 \text{ mm}^2) + 4 \times 0.16 \text{ mm}^2; A_P = 2 \times 0.16 \text{ mm}^2$		
With 8-pin M12 coupling (male)		729681-xx
With 15-pin D-sub connector (female)		1119394-xx

<b>Adapter cables and connecting cable</b> $\varnothing 6 \text{ mm}; 2 \times (2 \times 0.09 \text{ mm}^2) + 2 \times (2 \times 0.16 \text{ mm}^2); A_P = 2 \times 0.16 \text{ mm}^2$		
<b>Connecting cable</b> with 8-pin M12 connector (female) and 8-pin M12 coupling (male)		1036372-xx
<b>Adapter cable</b> with 8-pin M12 connector (female) and 15-pin D-sub connector (female)		1036521-xx
<b>Adapter cable</b> with 8-pin M12 connector (female) and 15-pin D-sub connector (male)		1036526-xx

$A_P$ : Cross section of power supply lines







$\varnothing$ : Cable diameter (for bend radii, see the *Interfaces of HEIDENHAIN Encoders* brochure)

**Note for safety-related applications:** Only completely assembled HEIDENHAIN cables are qualified.

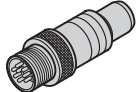
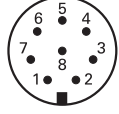
Do not modify cables or exchange their connectors without first consulting with HEIDENHAIN Traunreut.

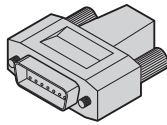
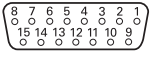
For more cables, see the *Angle Encoders with Integral Bearing* brochure.

## Pin layout

8-pin M12 coupling					15-pin D-sub connector			
								
	Voltage supply				Absolute position values			
	8	2	5	1	3	4	7	6
	1	9	2	11	5	8	14	15
	$U_P$	Sensor $U_P$	0V	Sensor 0V	DATA	$\overline{\text{DATA}}$	CLOCK	$\overline{\text{CLOCK}}$
	Brown/Green	Blue	White/Green	White	Gray	Pink	Violet	Yellow

**Cable shield** connected to housing;  $U_P$  = Power supply voltage

**Sensor:** The sense line is connected in the encoder with the corresponding power line.

Vacant pins or wires must not be used!

---

# HEIDENHAIN

**DR. JOHANNES HEIDENHAIN GmbH**

Dr.-Johannes-Heidenhain-Straße 5

**83301 Traunreut, Germany**

☎ +49 8669 31-0

☎ +49 8669 32-5061

E-mail: [info@heidenhain.de](mailto:info@heidenhain.de)

---

**[www.heidenhain.de](http://www.heidenhain.de)**

This Product Information document supersedes all previous editions, which thereby become invalid. The basis for ordering from HEIDENHAIN is always the Product Information document edition valid when the order is made.



## More information:

Comply with the requirements described in the following documents to ensure the correct operation of the encoder:

- Brochure: *Angle Encoders with Integral Bearing* 591109-xx
  - Brochure: *Interfaces of HEIDENHAIN Encoders* 1078628-xx
  - Mounting instructions: RCN 2310/2510 765742-xx  
RCN 5310/5510 765743-xx  
RCN 8310/8510 (Ø 60 mm) 765744-xx  
RCN 8310/8510 (Ø 100 mm) 765745-xx
  - Safety-Related Position Measuring Systems Technical Information 596632-xx
- For implementation in a control:
- Specification for safe control 533095-xx

For brochures and product information sheets, visit **[www.heidenhain.de](http://www.heidenhain.de)**.