

РЕМСТАНМАШ
ТЕХНОЛОГИИ ДЛЯ ПРОИЗВОДСТВА

ООО «РемСтанМаш»

Адрес: г. Смоленск, улица Верхне-Сенная улица, дом 4, офис № 409.
Телефон: 8-800-511-02-67
Телефон: +7-919-0-46-48-46
E-mail: info@cnchelp.ru
Сайт: www.cnchelp.ru



Product Information

LIP 6000

Exposed Linear Encoders

LIP 6071, LIP 6081

Incremental linear encoders with very high accuracy

- For limited installation space
- For measuring steps to 2 nm
- For high traversing speeds and large measuring lengths
- Position detection through homing track and limit switches
- Measuring standard is fastened by adhesive or fixing clamps

Mounting without limit clips

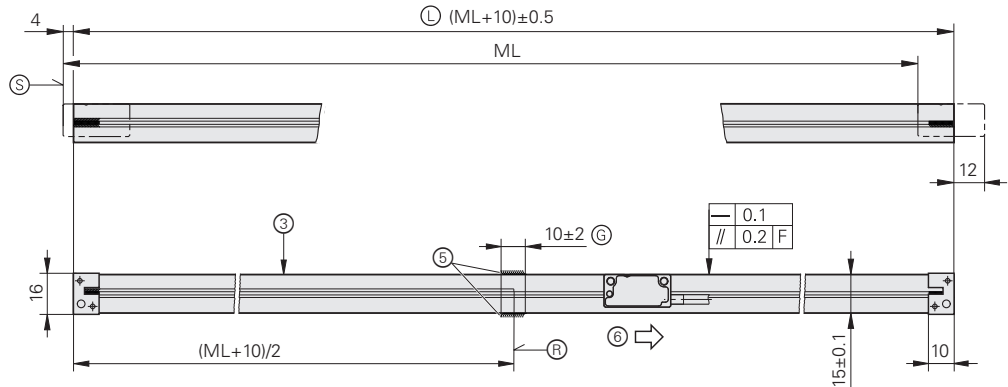

Mounting with limit clips

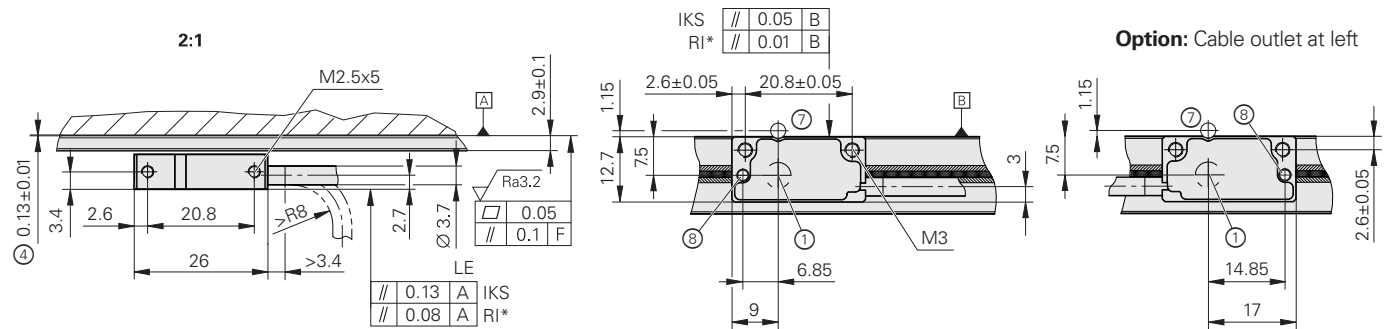

Position of the stop pins

ML ≤ 2040

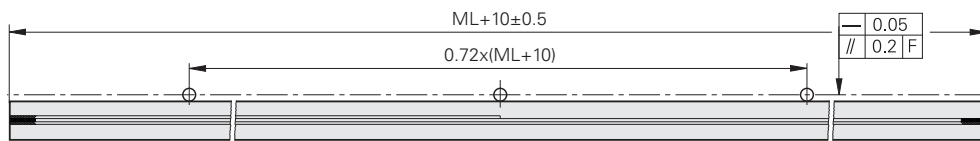

ML > 2040

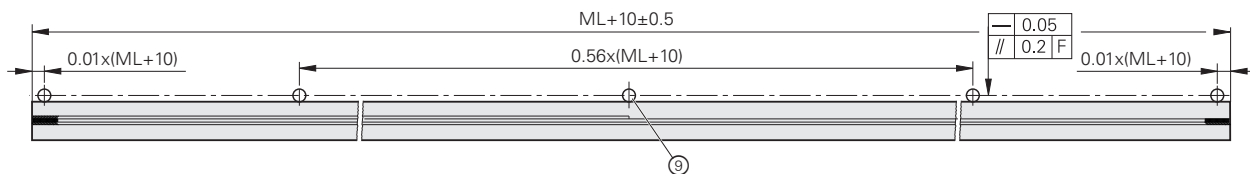

Possibilities for mounting the scanning head

Shown without fixing clamps

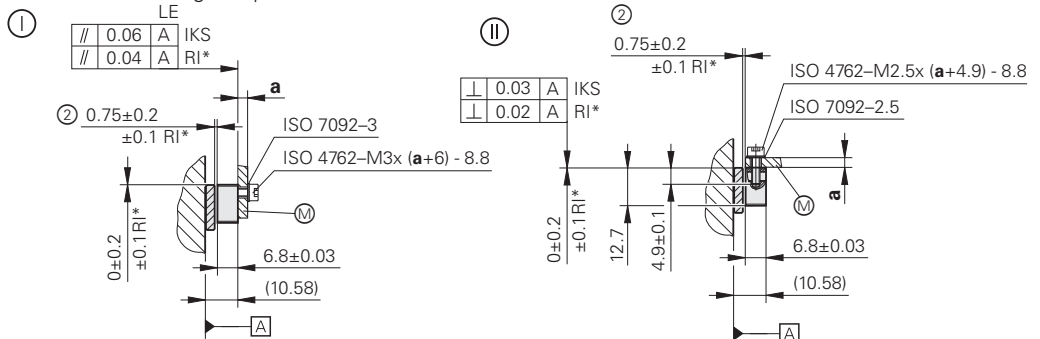

mm

 Tolerancing ISO 8015
 ISO 2768 - m H
 ≤ 6 mm: ±0.2 mm

- F = Machine guideway
- * = Max. change during operation
- IKS = Incremental track
- RI = Reference mark track
- M = Mounting surface
- Ⓛ = Scale length
- Ⓢ = Beginning of measuring length ML
- Ⓤ = Fixed-point for defining the thermal fixed point
- ① = Optical center
- ② = Mounting clearance of scanning head to scale; adjusted by means of a space shim
- ③ = Scale stop surface
- ④ = Adhesive tape
- ⑤ = Adhesive
- ⑥ = Direction of scanning unit as per interface description
- ⑦ = Moiré adjustment option 1: Alignment pin, Ø 3m6, possible only with mounting option ①
- ⑧ = Moiré adjustment option 2: Alignment pin, Ø 2m6, possible only with mounting option ①
- ⑨ = Recommendation: Ø 3

Mounting without limit clips

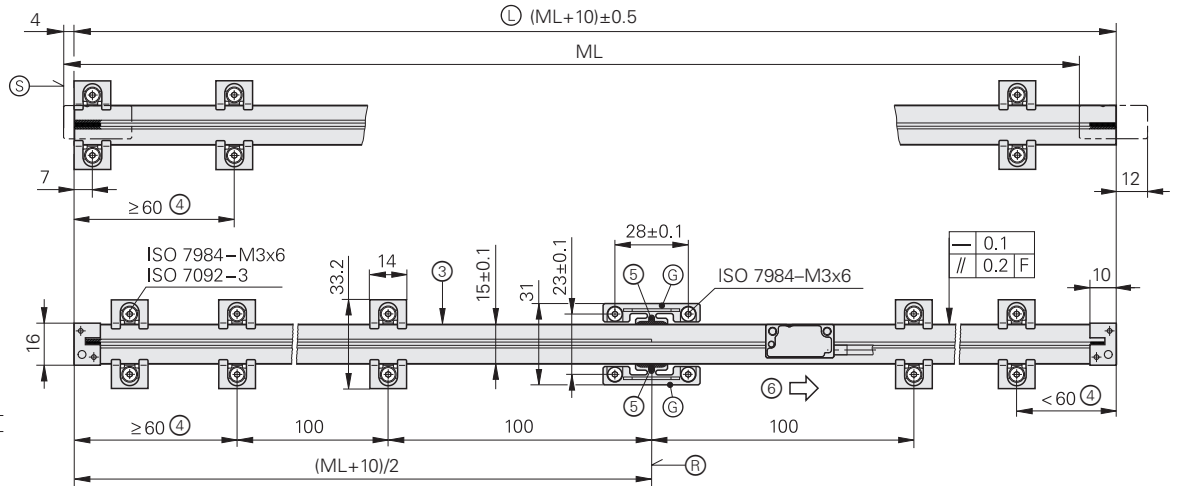

Mounting with limit clips
2:1

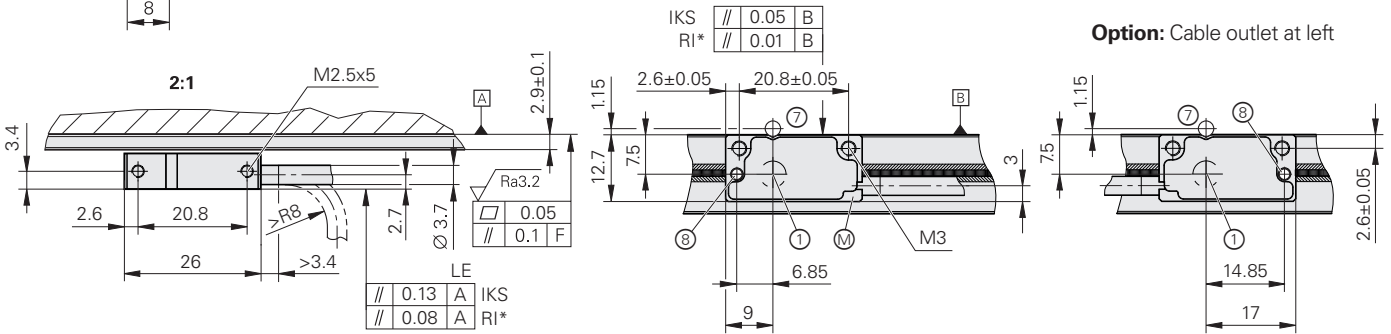
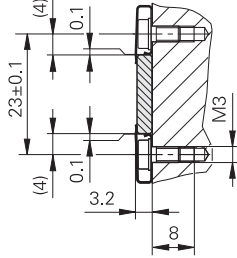

Option: Cable outlet at left

Position of the stop pins

ML ≤ 2040

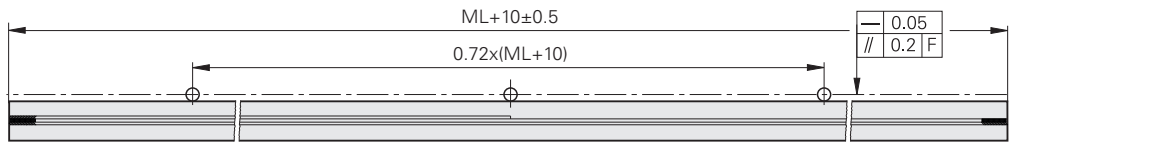

ML > 2040

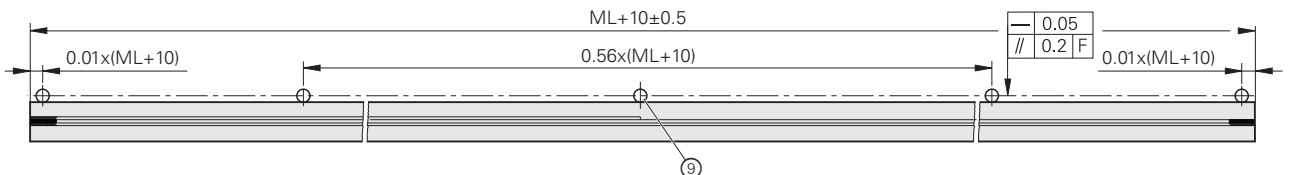

Possibilities for mounting the scanning head
Shown without fixing clamps

mm
Tolerancing ISO 8015
ISO 2768 - m H
≤ 6 mm: ±0.2 mm

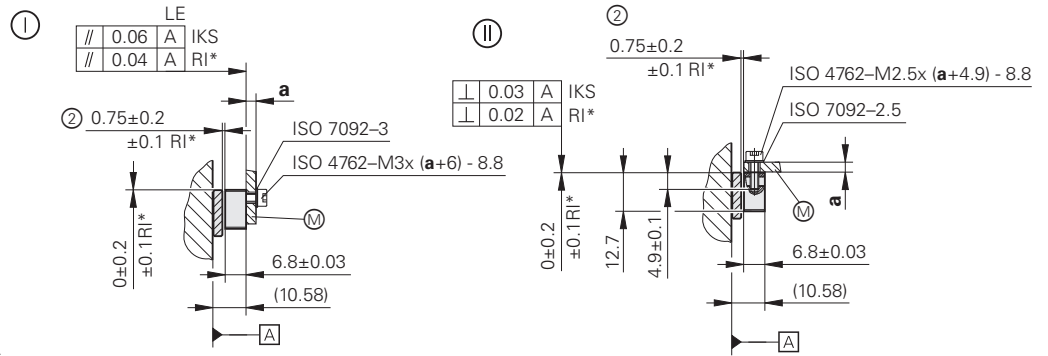

- F = Machine guideway
- * = Max. change during operation
- IKS = Incremental track
- RI = Reference mark track
- M = Mounting surface
- L = Scale length
- S = Beginning of measuring length ML
- G = Fixed-point element for defining the thermal fixed point
- 1 = Optical center
- 2 = Mounting clearance of scanning head to scale; adjusted by means of a space shim
- 3 = Scale stop surface
- 4 = Use additional fixing clamp pairs depending on the measuring length (ML)
- 5 = Adhesive
- 6 = Direction of scanning unit as per interface description
- 7 = Moiré adjustment option 1: Alignment pin, Ø 3m6, possible only with mounting option 1
- 8 = Moiré adjustment option 2: Alignment pin, Ø 2m6, possible only with mounting option 1
- 9 = Recommendation: Ø 3



Scale	LIP 6001
Measuring standard* Coefficient of linear expansion	OPTODUR phase grating on Zerodur glass ceramic; grating period 8 µm $\alpha_{\text{therm}} = (0 \pm 0.1) \times 10^{-6} \text{ K}^{-1}$ (Zerodur glass ceramic) $\alpha_{\text{therm}} \approx 8 \times 10^{-6} \text{ K}^{-1}$ (glass)
Accuracy grade*	±1 µm (only for Zerodur glass ceramic up to measuring length 1020 mm); ±3 µm
Baseline error	≤ ±0.175 µm/5 mm
Measuring length ML* in mm	20 30 50 70 120 170 220 270 320 370 420 470 520 570 620 670 720 770 820 870 920 970 1020 1140 1240 1340 1440 1540 1640 1840 2040 2240 2640 2840 3040
Reference mark	One at midpoint of measuring length
Mass	1.1 g + 0,11 g/mm overall length







Scanning head	AK LIP 608	AK LIP 607					
Interface	~ 1 V _{PP}	TTL ¹⁾					
Integrated interpolation* signal period	– 4 µm	5-fold 0.8 µm	10-fold 0.4 µm	25-fold 0.16 µm	50-fold 0.08 µm	100-fold 0.04 µm	500-fold 0.008 µm
Cutoff frequency –3 dB	≥ 1 MHz						
Scanning frequency	–	– ≤ 625 kHz	≤ 625 kHz ≤ 312.5 kHz ≤ 156.25 kHz	≤ 250 kHz ≤ 125 kHz ≤ 62.5 kHz	≤ 125 kHz ≤ 62.5 kHz ≤ 31.25 kHz	≤ 62.5 kHz ≤ 31.25 kHz ≤ 15.63 kHz	≤ 12.5 kHz ≤ 6.25 kHz ≤ 3.13 kHz
Edge separation <i>a</i>	–	– ≥ 0.07 µs ≥ 0.135 µs	≥ 0.03 µs ≥ 0.07 µs ≥ 0.135 µs				
Traversing speed ²⁾	≤ 240 m/min	– ≤ 150 m/min ≤ 75 m/min	≤ 150 m/min ≤ 75 m/min ≤ 37 m/min	≤ 60 m/min ≤ 30 m/min ≤ 15 m/min	≤ 30 m/min ≤ 15 m/min ≤ 7.5 m/min	≤ 15 m/min ≤ 7.5 m/min ≤ 3.7 m/min	≤ 3 m/min ≤ 1.5 m/min ≤ 0.75 m/min
Interpolation error Position noise RMS	± 4 nm 0.4 nm ³⁾	–					
Voltage supply	DC 5 V ± 0,5 V						
Current consumption	≤ 150 mA	≤ 250 mA (without load)					
Cable length	With HEIDENHAIN cable: Homing, limit: ≤ 10 m; only incremental: ≤ 20 m; during signal adjustment with PWM 21: ≤ 3 m						
Electrical connection*	Cable, 0.5 m, 1 m or 3 m with D-sub connector (male) 15-pin; with AK LIP 607 interface electronics in connector; cable outlet at left, right, straight or right-angle						
Vibration 55 Hz to 2000 Hz Shock 6 ms	≤ 500 m/s ² (IEC 60068-2-6) ≤ 1000 m/s ² (IEC 60068-2-27)						
Operating temperature	–10 °C to 70 °C						
Protection EN 60529	IP50						
Mass	Scanning head Connector Connecting cable	≈ 5 g (without cable) AK LIP 608 ≈ 71 g; AK LIP 607 ≈ 74 g ≈ 22 g/m					

* Please select when ordering
¹⁾ TTLx1 unlocked possible upon request

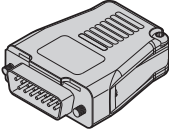
²⁾ Only for TTL: Maximum traversing speed for referencing: 16.8 m/min (70 kHz)
³⁾ 1 MHz with –3 dB cutoff frequency of the subsequent electronics

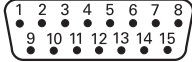
Electrical connection

LIP 6071/6081 pin layout

15-pin D-sub connector														
														
Voltage supply				Incremental signals						Other signals				
	4	12	2	10	1	9	3	11	14	7	13	8	6	15
 TTL	U _p	Sensor 5 V	0 V	Sensor 0 V	U _{a1}	\overline{U}_{a1}	U _{a2}	\overline{U}_{a2}	U _{a0}	\overline{U}_{a0}	\overline{U}_{aS}	H	L	PWT ¹⁾
 1V _{pp}	● — ●		● — ●		A+	A-	B+	B-	R+	R-	As- signed			As- signed
	Brown/ Green	Blue	White/ Green	White	Brown	Green	Gray	Pink	Red	Black	Violet	Green/ Black	Yellow/ Black	Yellow



Cable shield on housing; **U_p** = Power supply voltage

¹⁾ Conversion of TTL/11 μApp for PWT

Sensor: The sensor line is connected in the encoder with the corresponding power line

Unused pins or wires must not be assigned!

Connecting cables

PUR connecting cable [6(2 × 0,09 mm ²) + (4 × 1,4 mm ²)] A _V = 0,14 mm ²			
PUR connecting cable [6(2 × 0,14 mm ²) + (4 × 0,5 mm ²)] A _V = 0,5 mm ²		∅ 8 mm	∅ 6 mm ¹⁾
With one D-sub connector (female), 15-pin		354411-xx	355398-xx
Complete with D-sub connector (female), and D-sub connector (male), 15-pin		354379-xx	355397-xx

¹⁾ Max. total cable length 9 m

A_V: Cross section of power supply lines

HEIDENHAIN

DR. JOHANNES HEIDENHAIN GmbH

Dr.-Johannes-Heidenhain-Straße 5

83301 Traunreut, Germany

☎ +49 8669 31-0

FAX +49 8669 32-5061

E-mail: info@heidenhain.de

www.heidenhain.de

This Product Information supersedes all previous editions, which thereby become invalid. The basis for ordering from HEIDENHAIN is always the Product Information document edition valid when the order is made.



For more information:

Comply with the requirements described in the following documents to ensure the correct operation of the encoder:

- Brochure: *Interfaces of HEIDENHAIN Encoders*
- Brochure: *Exposed Linear Encoders*

1078628-xx
208960-xx