

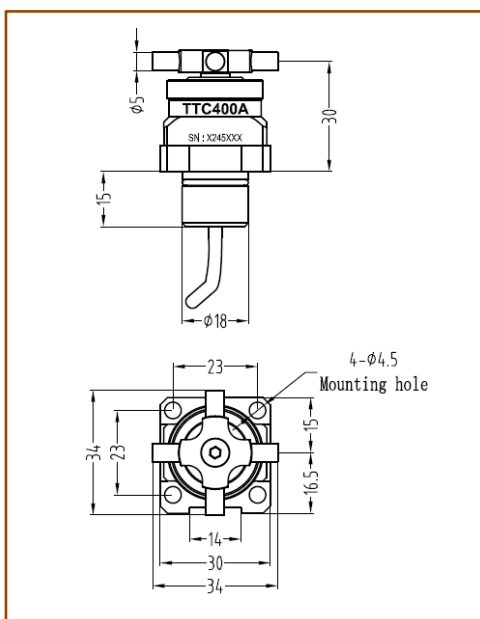

### Installing structure of the unit

TTC400A cable tool setter unit is a product specially developed by our company for replacing some vulnerable tool setting units that is part of the swing-arm for setting the cutting tool in the CNC lathes; The structure and size of the installing parts are exactly the same as the replacement, and the output signal is exactly the same.

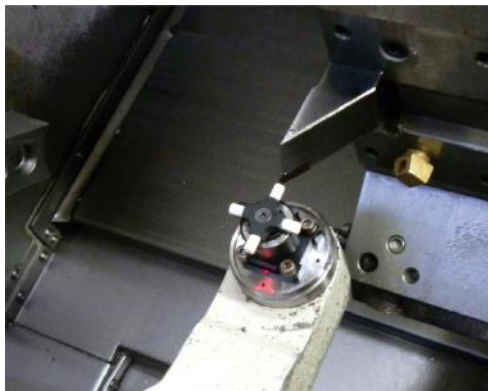

### Technical Parameters

- ◆ The diameter of the four ceramic touching pillar( for cutting tool touching): 5.0 mm; the pillars' hardness : HM8.5;
- ◆ Sensing direction of the pillars:  $\pm X, \pm Z$ ;
- ◆ The pillars sensing over-travel :  $X-Z \pm 5$  mm;
- ◆ The trigger repeatability of the pillar( $2\sigma$ ):  $\leq 2$   $\mu$ m;
- ◆ Input voltage is  $24 \pm 10\%$  V DC and output load current is 50 mA;
- ◆ Signal model and LED instruction: high electric level output with normal signal state, LED normally on; When any one pillar is triggered, the signal output point is suspended and the LED is off;
- ◆ Seal grade: IP68.

### Technical Characteristics

- ◆ As shown in the picture, the installing structure and size of the tool setter unit are exactly the same as the replacement;
- ◆ Tool setter unit transmits tool setting signal through cable;
- ◆ It is ensured during manufacturing that the position relationship between four pillars of the tool setter unit and mounting base;
- ◆ One LED indicator light is used to display the tool setter's working state.

### Application

- ◆ Set parameters of cutting tools automatically before CNC processing;
- ◆ Detect wear and breakage of cutting tools automatically between two processes or after the CNC processing;
- ◆ Through checking cutting tool parameters to control the change of machining precision from the temperature change of the machine;
- ◆ Applicable equipments: various specifications of CNC lathe, turning machine center and CNC milling -turning center;
- ◆ The cable: TTC400A tool setter unit is equipped a 6 meter-long, three-core, anti-oil shielded cable.

### Notes for purchase

- ◆ As for the cable length, verify whether the cable length equipped is enough for installing the tool setter unit on your machine tool; If lengthening cable is needed, special instructions should be given when ordering the product;

