

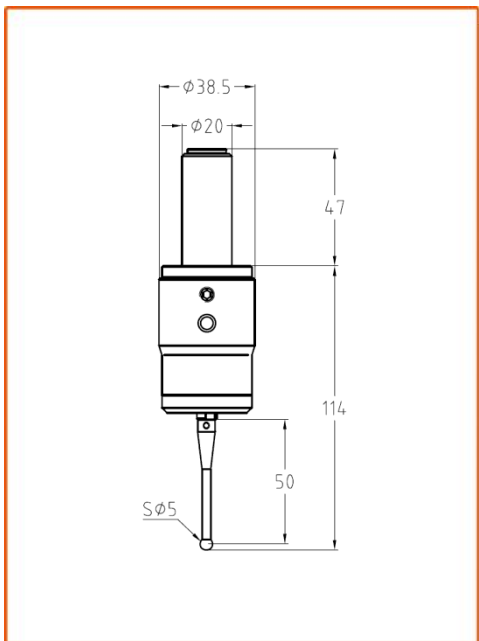

EP40 Electric probe

Composition of Probe

- 1) EP40 electric conducting probe has a cylindrical shank of 20mm diameter (the specification is optional);
- 2) Stylus(standard model: M4-S50-CB5-S30).

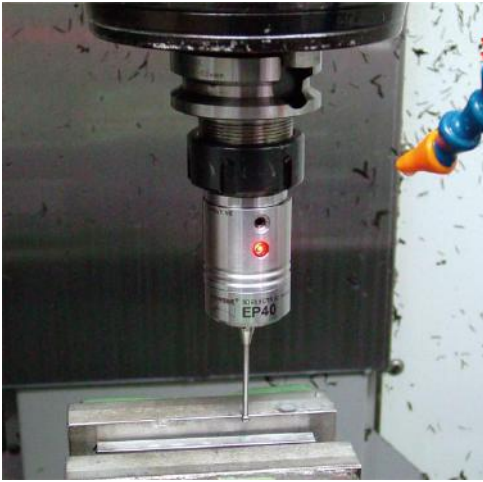

Technical Parameters

- ◆ Stylus sensing direction: $\pm X, \pm Y, +Z$;
- ◆ Stylus sensing over-travel : $X-Y \pm 15^\circ$, $Z +5$ mm;
- ◆ The trigger force in Z direction: 1000 g;
- ◆ Trigger force in X-Y surface (standard stylus) : 65-130g;
- ◆ Unidirectional repeatability (2σ) : $\leq 2 \mu\text{m}$;
- ◆ Seal grade: IP68.

Technical Characteristics

- ◆ Coaxial adjustment function of probe and shank:
By adjusting the connecting link between the main body of the probe and its shank, coaxiality about the center of the measuring ball on the stylus and the center line of the shank can be adjusted (the factory precision: $\leq 5 \mu\text{m}$);
- ◆ Three LED indicator lights are used to show the trigger state of the probe.

Basic configuration

- ◆ The standard: M4-S50-CB5-S30;
- ◆ The diameter of the probe's cylindrical shank is 20 mm;
- ◆ Two batteries, model: LR1, 1.5V, 700 mAh.

Applicable equipment and working condition

- ◆ Suitable for various specifications of machine centers, CNC boring and milling machines, and drilling-tapping machine centers, etc;
- ◆ Suitable for checking work pieces of all kinds of solid materials with electrical conductivity.

Application

- ◆ Setting work-piece coordinate system and machining zero points manually before processing;
- ◆ Detect and control the key dimensions, position coordinates and their precision manually between two processes;
- ◆ Detect precision of the key dimensions, shapes, position after processing.

Notes for purchase

- ◆ As for special stylus, check whether the standard stylus equipped with the EP40 probe can meet the requirements and whether it is necessary to order special stylus;
- ◆ Verify that the spindle of the CNC machine tool whether uses ceramic bearings. If ceramic bearings are used, You should choose the TP60 trigger probe.